



输出功率：约0.1~1.6W
贵金属电刷马达/碳刷马达

典型应用：电子门锁
智能家居
精密仪器
减速箱

OUTPUT:APPROX0.1~1.6W
Precious Metal-brush Motors/Cabron-brush Motors

Typical Applications: Electronic Door Lock
Smart Home Appliance
Precision Instruments
Gear Box

1.OUTLINE DRAWING:

UNIT:MM

DIRECTION OF ROTATION

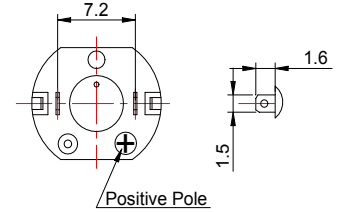
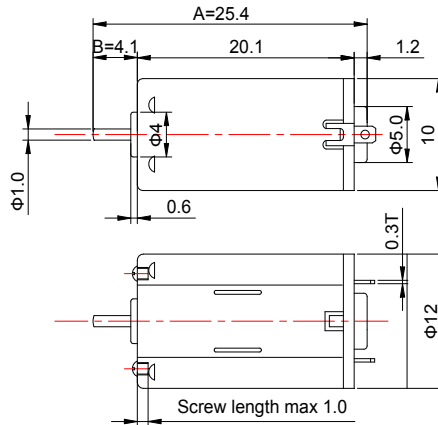
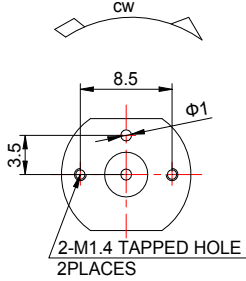

WEIGHT:7.6g(APPROX)

View:

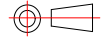

Customizable Parameters:

1. Length Aa B
2. Electric Performance
3. Direction of Rotation
4. Eccentric Wheel is available

2.MOTOR PERFORMANCE :

MODEL	VOLTAGE		NO LOAD		AT MAXIMUM EFFICIENCY					STALL		
	OPERATING RANGE	NOMINAL V	SPEED rpm	CURRENT A	SPEED rpm	CURRENT A	TORQUE g.cm	TORQUE mN.m	OUTPUT W	TORQUE g.cm	TORQUE mN.m	CURRENT A
FF-N30TA-06360	3.0~7.0	6.0	6000	0.01	4560	0.042	3	0.29	0.14	12.5	1.23	0.14
FF-N30TA-1566	2.0~4.0	3.0	15000	0.066	12600	0.35	4.2	0.41	0.54	26.5	2.60	1.875
FF-N30TA-10150	3.0~9.0	9.0	24500	0.036	20800	0.205	4.8	0.47	1.02	32	3.14	1.15
FF-N30TA-10140	3.0~7.0	6.0	17600	0.028	14850	0.15	3.2	0.31	0.49	20.6	2.02	0.82
FF-N30TA-09210	2.0~5.0	2.5	5200	0.026	4200	0.055	1.6	0.16	0.07	8.2	0.80	0.23
FF-N30TA-06425	3.0~13.0	12.0	12000	0.012	9800	0.055	3.5	0.34	0.35	19.5	1.91	0.23
FK-N30TA-10140	3.0~9.0	9.0	24500	0.036	20100	0.28	5.3	0.52	1.09	30	2.94	1.28
FK-N30TA-13100	3.0~6.0	5.0	16000	0.135	13300	0.33	5.8	0.57	0.79	35	3.43	1.65

